

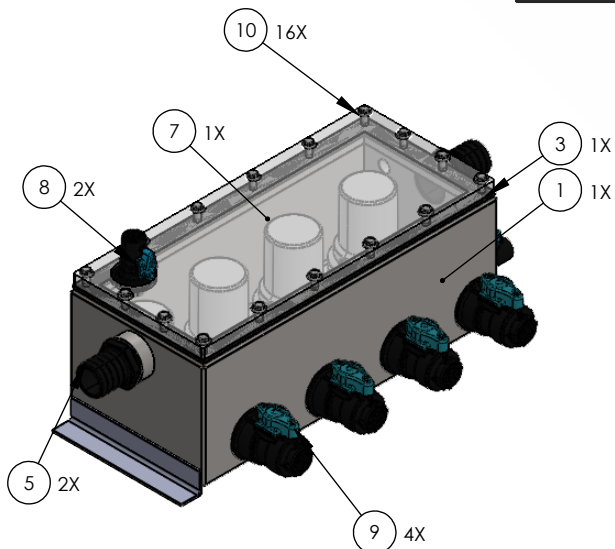

ITEM NO.	PART NUMBER	DESCRIPTION	QTY.
1	3704.7	21.5" PUMP BOX SS	1
3	40000G	SEA CHEST RUBBER GASKET 21.5"	1
4	92198A687	18-8 SS HEX SCREW 5/16"	16
5	90518	HOSE BARB STRAIGHT 2"X2" NPS LONG THREAD (OPTIONAL)	2
6	201-005-01	RULE PUMP 1500GPH /2000GPH 12V	4
7	40000	ACRYLIC LID 21.5"X9.625X0.75"	1
8	91376	BALL VALVE 3/4" NPS	2
9	91389	BALL VALVE 1in NPS	4
10	92141A030	18-8 SS 5/16" WASHER	16

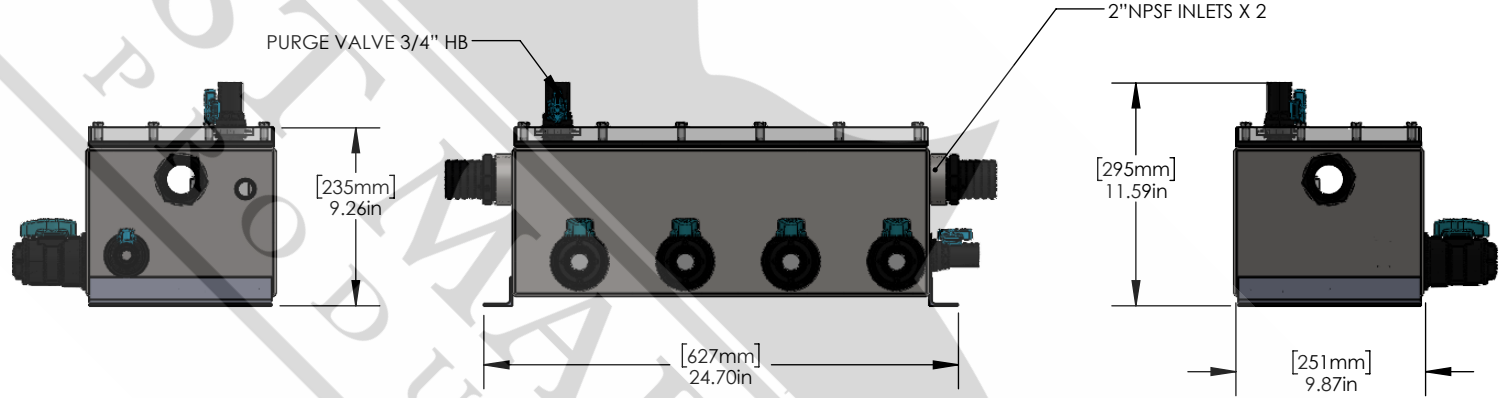
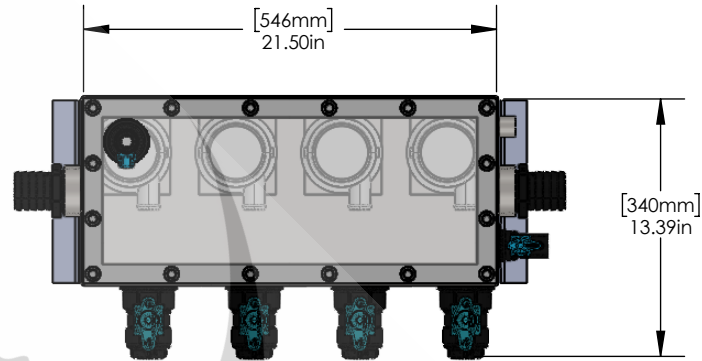

Material: STAINLESS STEEL 316 MARINE GRADE		This drawing and any information or descriptive material set out on it are the confidential and copyright property of BEST MARINE PRODUCTS LLC. © and MUST NOT BE DISCLOSED, COPIED, LOANED in whole or part or used for any purpose without the written permission of BEST MARINE PRODUCTS LLC.	Description: 1500GPH OR 2000GPH X4 PUMPS SEA CHEST	
Finish: POWDER COATED			Drawn by: SM	Drawn Date: 02/05/2026
Unless Otherwise Stated: Linear Tol.: ±0.2, Angular Tol.: 0°15' Surface Finish: 32 µin All Dimensions: in		Document Type:	Checked/Approved by: MP	Checked/Approved Date: 02/05/2026
Drawing Scale: 1:12		CONFIDENTIAL		Part Number: 31005/31006
Approx Weight: 90 lbs	Drawing Produced In Accordance With: ASME Y14.5	Legal Owner:  BEST MARINE PRODUCTS LLC. 18693 SW 103rd Ct, Cutler Bay, FL 33157, USA Tel: 305 255-0220 www.bestmarineproducts.com	Drawing Number:	Sheet: 1 of 1
Projection Method: THIRD ANGLE 	Sheet Size: A4			Revision: (-)