

1	2	3	4	5	6
ITEM NO.	PART NUMBER	DESCRIPTION	QTY.		
2	90376	HOSE BARB ELBOW 2" X 2" NPS LONG THREAD (OPTIONAL)	2		
3	201-005-01	RULE 3700-14 AM PUMP	4		
4	3704-G	RUBBER GASKET 80S SHORE	1		
5	3704.7	28" PUMP BOX SS	1		
6	202-006-15	SS HEX SCREWS 5/16" DIA	24		
7		5/16" DIA WASHER	24		
8	60000	ACRYLIC LID	1		
9	91389	BALL VALVE 1.5" NPS	4		
10	91376	BALL VALVE 3/4" NPS	2		

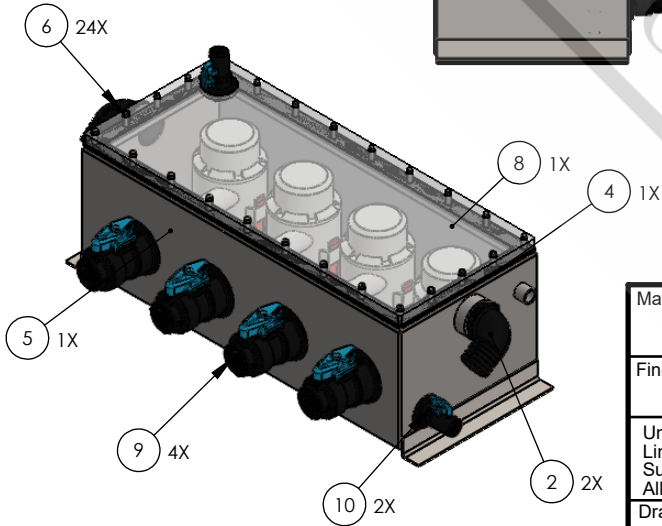
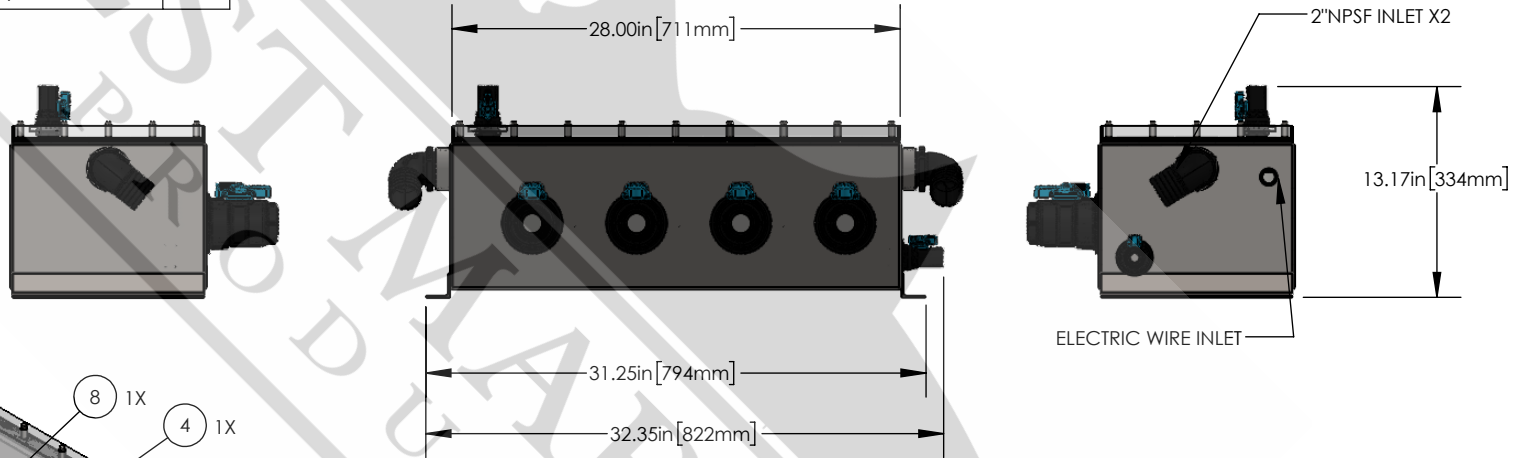
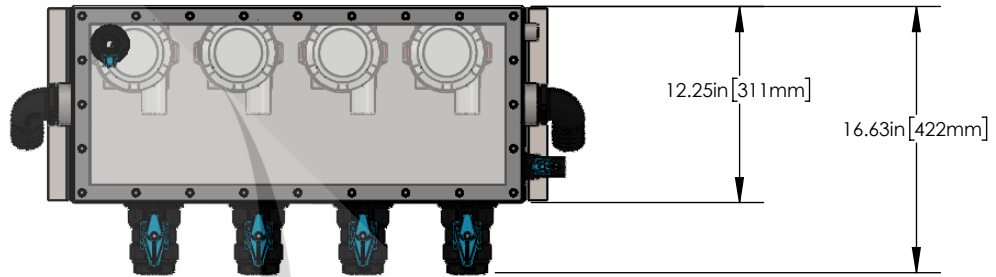

Material: STAINLESS STEEL 316 MARINE GRADE		This drawing and any information or descriptive material set out on it are the confidential and copyright property of BEST MARINE PRODUCTS LLC. © and MUST NOT BE DISCLOSED, COPIED, LOANED in whole or part or used for any purpose without the written permission of BEST MARINE PRODUCTS LLC.		Description: 3700GPH X4 PUMP SEA CHEST	
Finish: POWDER COATED		Document Type:		Drawn by: SM	Drawn Date: 01/20/2026
Unless Otherwise Stated: Linear Tol.: ±0.2, Angular Tol.: 0°15' Surface Finish: 32 µin All Dimensions: in		Drawing Scale: 1:12		Checked/Approved by: MP	Checked/Approved Date: 01/20/2026
Approx Weight: 90 lbs		Drawing Produced In Accordance With: ASME Y14.5		Part Number: 31011	
Projection Method: THIRD ANGLE		Sheet Size: A4		Drawing Number:	
		Legal Owner: BEST MARINE PRODUCTS LLC. 18693 SW 103rd Ct, Cutler Bay, FL 33157, USA Tel: 305 255-0220 www.bestmarineproducts.com		Sheet: 1 of 1	Revision: (-)