

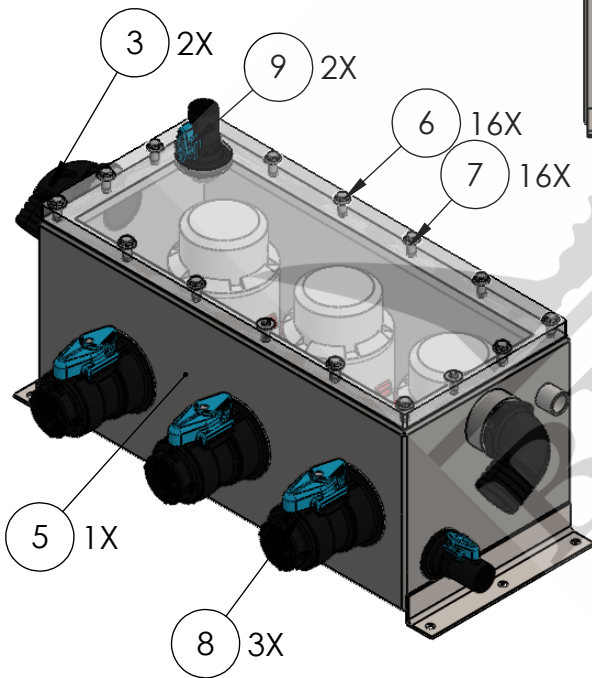

1	2	3	4	5	6
ITEM NO.	PART NUMBER	DESCRIPTION	QTY.		
2	40000	ACRYLIC LID 21.5"X9.625X0.75"	1		
3	90376	HOSE BARB ELBOW 2" X 2" NPS LONG THREAD (OPTIONAL)	2		
4	201-005-01	RULE 3700-14 AMP PUM	3		
5	3704.7	28" PUMP BOX SS	1		
6	92198A687	5/16-18 SS HEX HEAD SCREW 1-1/2"	16		
7	90107A030	5-16-18 SS WASHER	16		
8	91389	BALL VALVE 1.5" NPS	3		
9	91376	BALL VALVE 3/4" NPS	2		

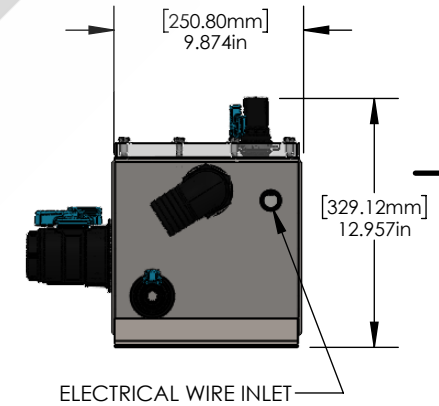
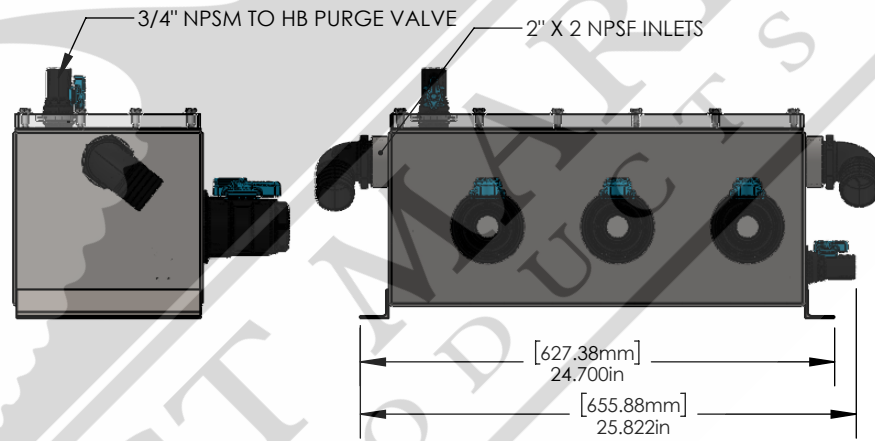
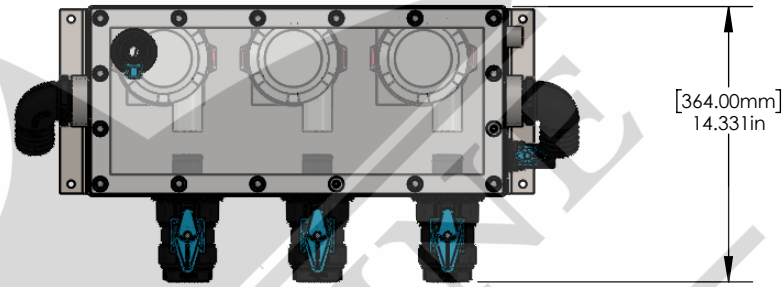

<b>Material:</b> STAINLESS STEEL 316 MARINE GRADE		This drawing and any information or descriptive material set out on it are the confidential and copyright property of <b>BEST MARINE PRODUCTS LLC.</b> © and <b>MUST NOT BE DISCLOSED, COPIED, LOANED</b> in whole or part or used for any purpose without the written permission of <b>BEST MARINE PRODUCTS LLC.</b>		<b>Description:</b> 3700X3 XL SEA CHEST	
<b>Finish:</b> POWDER COATED		<b>Document Type:</b> CONFIDENTIAL		<b>Drawn by:</b> SM	
Unless Otherwise Stated: Linear Tol.: ±0.2, Angular Tol.: 0°15' Surface Finish: 32 µin All Dimensions: in		<b>Legal Owner:</b>  BEST MARINE PRODUCTS LLC. 18693 SW 103rd Ct, Cutler Bay, FL 33157, USA Tel: 305 255-0220 www.bestmarineproducts.com		<b>Drawn Date:</b> 02/25/2026	
<b>Drawing Scale:</b> 1:8		<b>Part Number:</b> 31010		<b>Checked/Approved by:</b> MP	
<b>Approx Weight:</b> 61.00lbs.		<b>Drawing Produced In Accordance With:</b> ASME Y14.5		<b>Checked/Approved Date:</b> 02/25/2026	
<b>Projection Method:</b> THIRD ANGLE 		<b>Sheet Size:</b> A4		<b>Part Number:</b> 31010	
				<b>Drawing Number:</b> 1 of 1	
				<b>Sheet:</b> 1 of 1	
				<b>Revision:</b> (-)	