

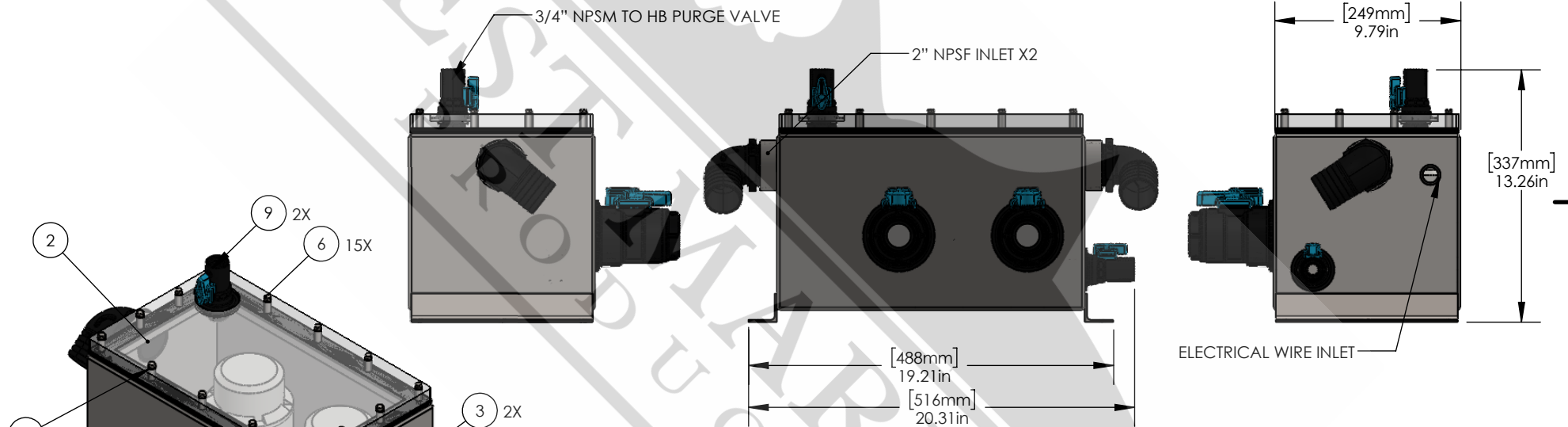

1		2		3		4		5		6	
ITEM NO.	PART NUMBER	DESCRIPTION	QTY.								
2	30000.1	ACRYLIC LID 16"X9.625"X0.75"	1								
3	90376	HOSE BARB ELBOW 2" X 2" NPS LONG THREAD (OPTIONAL)	2								
4	201-005-01	RULE 3700-14 AMP PUM	2								
5	3702.7	16" PUMP BOX SS	1								
6	202-006-15	SS HEX SCREWS 5/16" DIA	15								
7	94709A153	5/16" DIA WASHER	15								
8	91389	BALL VALVE 1.5" NPS	2								
9	91376	BALL VALVE 3/4" NPS	2								
10	30000G	SEA CHEST GASKET LID 16"X9.625" RUBBER 80GAUGE	1								

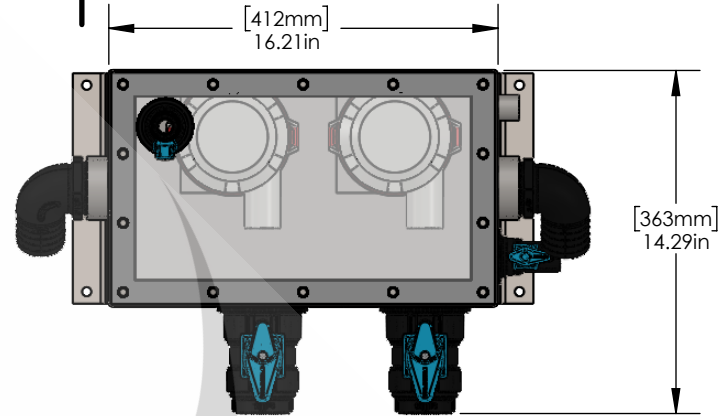

Material: STAINLESS STEEL 316 MARINE GRADE		This drawing and any information or descriptive material set out on it are the confidential and copyright property of <b>BEST MARINE PRODUCTS LLC.</b> © and MUST NOT BE DISCLOSED, COPIED, LOANED in whole or part or used for any purpose without the written permission of <b>BEST MARINE PRODUCTS LLC.</b>		Description: 3700GPHX2 SEA CHEST	
Finish: POWDER COATED		Document Type:		Drawn by: SM	Drawn Date: 01/23/2025
Unless Otherwise Stated: Linear Tol.: ±0.2, Angular Tol.: 0°15' Surface Finish: 32 µin All Dimensions: in		Drawing Scale: <b>1:8</b>		Checked/Approved by: MP	Checked/Approved Date: 01/23/2025
Approx Weight: 42.00 lbs	Drawing Produced In Accordance With: <b>ASME Y14.5</b>	Legal Owner: <b>BEST MARINE PRODUCTS LLC.</b>		Part Number: 31009	
Projection Method: <b>THIRD ANGLE</b>	Sheet Size: <b>A4</b>	BEST MARINE PRODUCTS LLC. 18693 SW 103rd Ct, Cutler Bay, FL 33157, USA Tel: 305 255-0220 www.bestmarineproducts.com		Drawing Number:	Sheet: <b>1 of 1</b>
					Revision: (-)